

# **YOMANI Touch XR Autonom, Compact, Pinpad**

**User guide**

# Table of contents

<b>1</b>	<b>Security requirements</b>	3
1.1	Electromagnetic compatibility	3
1.2	Where wireless technologies are used	3
<b>2</b>	<b>Product info</b>	4
2.1	Customer terminal	4
2.2	Cash register terminal (YOMANI Touch XR Autonom)	4
2.3	Abbreviations/Information	5
2.4	Payment procedure with ep2	6
2.5	Technical information	6
<b>3</b>	<b>Start-up</b>	7
3.1	Installation	7
3.2	Configuration/Initialization	8
<b>4</b>	<b>Menu tree (illustration)</b>	9
4.1	Main menu	9
4.2	Transactions	10
<b>5</b>	<b>Transactions</b>	11
5.1	Purchase	11
5.2	Purchase authorized per phone	15
5.3	Cancellation	15
5.4	Credit	16
5.5	Additional transactions	16
<b>6</b>	<b>Balances</b>	17
6.1	Start user shift/end user shift, daily closing, data transmission	17
<b>7</b>	<b>Queries (totals), settings</b>	18
<b>8</b>	<b>Setup</b>	19
<b>9</b>	<b>Additional services</b>	20
<b>10</b>	<b>Maintenance and handling</b>	21
10.1	Identifying and solving errors	21
10.2	Changing the paper roll	22

# 1 Security requirements

## 1.1 ELECTROMAGNETIC COMPATIBILITY

When connecting additional or other components the guidelines of the “Electromagnetic Compatibility Directive” (EMC) must be adhered to.

## 1.2 WHERE WIRELESS TECHNOLOGIES ARE USED

### While driving

Radio frequencies can interfere with electronic systems in vehicles, such as car radios or security devices, etc.

### Vehicles equipped with airbags

An enormous force is released when airbags are activated. Therefore, do not place the terminal in the area above the airbag or in the space in which the airbag could deploy. Terminals that are improperly installed can cause serious injury upon deployment of an airbag.

### Electronic devices

Most morn electronic devices, such as those used in hospitals and vehicles, are protected against radio frequencies. However, this is not the case with all electronic devices. Do not use your terminal in the proximity of medical equipment without obtaining prior permission.

### Heart pacemaker/other medical devices

Terminals can affect the functioning of implanted heart pacemakers and other medically implanted devices. Patients with a heart pacemaker should be informed that the use of terminals in the immediate vicinity of a pacemaker can lead to malfunctions. Do not pass the terminal over the pacemaker. The risk of a malfunction however, is minor if a minimum distance of 15 cm between the terminal and the pacemaker is maintained. If you suspect that malfunctions are occurring, put the terminal aside. If necessary, consult your cardiologist. If other medical devices are used in or on the body, then the equipment manufacturer should be consulted as to whether such devices are sufficiently protected against radio frequency signals. Do not use the terminal where the devices are implanted.

### Hearing aids

Under certain circumstances, terminals can cause some hearing aids to malfunction. Contact the dealer/manufacturer of your hearing aid.

### Other medical equipment

If you use a medical device, please contact the manufacturer to determine whether it is sufficiently protected against electromagnetic waves. If necessary, your attending physician could be helpful in obtaining this information. Equipment is often used in hospitals, medical offices and other facilities which is highly sensitive to external electromagnetic waves. Do not use the terminal in such locations.

### Aeroplanes

To avoid interfering with the communication systems, do not use the terminal during the flight. Only activate the terminal on the ground with permission from the ground personnel.

### Potentially explosive areas

Do not use the terminal in explosive zones or areas bearing signs with “Switch off sending/receiving devices”. Do not use the terminal in such potentially explosive locations.

### Appropriately marked locations

Follow instructions and do not use the terminal in locations with obvious signs and instructions prohibiting such use.

Every effort has been made to ensure that the information in this document is complete and exact at the date of printing. Further developments in the field of electronic payment traffic and technological progress could result in changes that might deviate from the description in this user guide.

Consequently, Worldline accepts no responsibility for the information provided in the operating instructions being current, complete or

correct. Furthermore, to the extent permitted under the relevant legal provisions, Worldline accepts no responsibility in connection with the operating instructions. The menu navigation on the terminal has been designed to be self-explanatory, making this document necessary only in case of emergency.

The latest version of the user guide, together with any updates, can be found on our homepage at: [worldline.com/merchant-services](https://worldline.com/merchant-services)

## 2 Product info

### 2.1 CUSTOMER TERMINAL



- 1 Thermal printer**  
(YOMANI Touch XR Compact only)
- 2 Chip reader**  
For chip cards
- 3 Magnetic strip reader**  
For cards with magnetic strips
- 4 Display**  
The next step to be taken is always shown on the display.
- 5 Navigation and function buttons**  
In some cases three symbol keys appear on the display. Use these to navigate through the menu (up/down/confirmation).
- 6 Contactless reader**  
Contactless payments can be carried out with the reader on the side of the terminal.
- 7 <OK> button**  
All entries must be confirmed using the <OK> button.
- 8 <CORR> button**  
Incorrect entries can be corrected using the <CORR> button.
- 9 <STOP> button**  
Active procedures can be stopped using this button.

### 2.2 CASH REGISTER TERMINAL (YOMANI TOUCH XR AUTONOM)



- 1 Thermal printer**
- 2 Screen**  
The next step to be taken is always shown on the screen.
- 3 Navigation and function buttons**  
You can use these buttons to move up and down in the menu.
- 4 <STOP> button**  
Active procedures can be stopped using this button.
- 5 <CORR> button**  
Incorrect entries can be corrected using the <CORR> button.
- 6 <OK> button**  
All entries must be confirmed using the <OK> button.

## 2.3 ABBREVIATIONS/INFORMATION

Cards with a chip	Cards which store the information needed for electronic payment on a chip must be inserted in a chip reader, depending on the terminal model. If the terminal is equipped with a motor reader, then the card is automatically drawn in and read.
Cards with a contactless chip	Cards that have a chip featuring a contactless function can be held up to contactless readers to speed up the payment process.
Cards with a magnetic stripe	Cards which store the information needed for electronic payment on a magnetic stripe must be swiped through the magnetic reader, depending on the terminal model. If the terminal is equipped with a motor reader, then the card is automatically drawn in and read.
CC	Computer center
CCC	Credit card company
CLP	Contactless payment
CrC	Credit cards
CVC/CVV	Card Verification Code/Card Verification Value number used to identify the card.
DCC	Dynamic Currency Conversion. International cardholders can pay in their card currency.
EFT/POS	Electronic Funds Transfer at the Point Of Sale
EMV	Global specifications from Eurocard, Mastercard and Visa based on a chip card.
ep2	<EFT/POS 2000>, Swiss standard based on the EMV standard in electronic payment traffic.
GPRS	General Packet Radio Service (GPRS) is a packet-oriented transmission service that is used in the field of mobile telephone systems.
GSM	Global Standard for Mobile Communications
NFC	Near Field Communication
Online transaction	An online transaction is always directly authorised at the CCC.
Offline transaction	An offline transaction is authorised in interdependence with the card and terminal risk management (e.g. if the amount of the previous transactions is less than the card limit or if the amount is less than the terminal floor limit on the card, etc.).
PIN	Personal Identification Number
PIN-based transaction	For a PIN-based transaction, the customer must enter his/her PIN at the point of sale during the payment process.
PW	Password
PUK	Personal Unblocking Key
TFP	Tax-Free Provider with whom the retailer uses the optional Tax-Free Service.
TFS	The Tax-Free Service, which is optionally performed by one of the supported Tax-Free Providers.
TIP	Tip
Trm	Terminal
Trx	Transaction
WLAN	A Wireless Local Area Network is a "wireless" local radio network, which generally refers to a standard within the IEEE 802.11 family.

## 2.4 PAYMENT PROCEDURE WITH EP2

The payment process at the point of sale is standardised for all cards with ep2. a variety of card types are in circulation today.

### Payment functions

ep2 offers a full range of transaction modes and functions. The transactions activated on your terminal are determined by the settings in the service centre as global parameters and by the individual card processors.

e.g. Tip:

This transaction type is often used in the hotel and restaurant industry. In the retail business, however, it is unnecessary.

- Depending on the payment function and credit card processor, different minimum/maximum amounts, day limits, etc. can be defined.
- Functions are described in general in the sections that follow. Please note that some transaction modes and functions may be inactive on your terminal.

### Caution for offline transactions!

Offline transactions are stored in the security section of your terminal and submitted to the card processor by means of the daily closing. This can be carried out manually by the terminal operator or automatically.

**Should the security section of the device be defective, intentionally damaged or stolen, the transactions that have not been stored will be lost.**

For this reason, we recommend that you:

- Meticulously retain all sales slips.
- Carry out a daily closing every day or more often.
- Always carry out a daily closing before making installation changes, etc.
- Always carry out a daily closing for anticipated longer absences from the business.
- A closing must be carried out for seasonal operations, at the end of the season.

## 2.5 TECHNICAL INFORMATION

### Operating temperature

0 °C to 50 °C

### Humidity (not condensing)

20% to 90%

### Power supply via power supply unit

100–250 VAC, 47–63 Hz

### Power supply through USB (except for YOMANI Touch XR)

5 V, 500 mA

### Storage

–10 °C to 60 °C

# 3 Start-up

## 3.1 INSTALLATION

- Position the device at its intended location
- Connect the device.  
Always plug in the power supply last!
- Cable:

Only the original cables supplied with the product should be used.

### Customer terminal

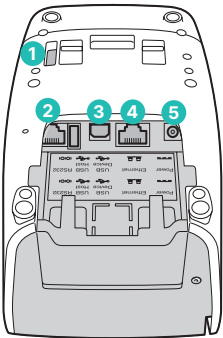

- 1 Port for NFC antenna (for contactless paying)
- 2 Serial RS-232 port
- 3 USB port
- 4 YOMANI Touch XR Pinpad and Compact only
- 5 Ethernet/LAN port

### Merchant unit (YOMANI Touch XR Autonom)

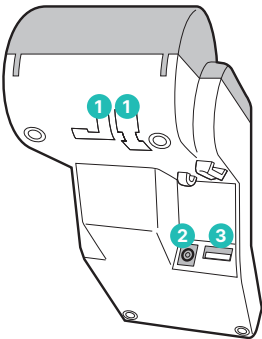

- 1 Cable guides
- 2 Power supply port
- 3 Customer terminal port

### Completed installation

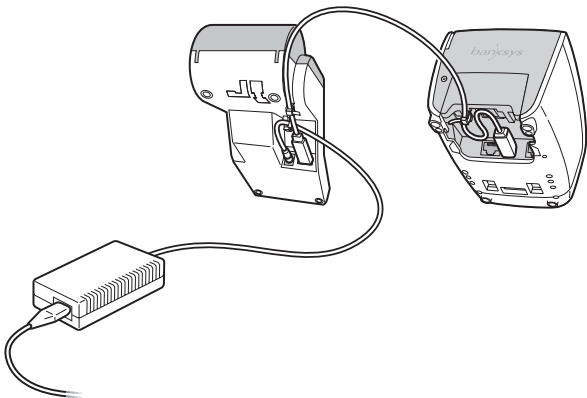

The terminal starts up und reports with an acoustic signal when it is ready to operate.

## 3.2 CONFIGURATION/INITIALIZATION

### First initialisation







The YOMANI Touch XR will generally already have been commissioned by the Worldline production facility. Additional instructions are provided to you in the "Configuration instructions for YOMANI Touch XR" delivered along with the terminal.

### Subsequent initialisation

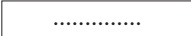
Should it be necessary to re-initialise a device for any reason, proceed as outlined on [page 19](#).

### Key

The following symbols are used in the descriptions in this document.

	Function selection by choosing the corresponding number or using the cursor and the <OK> button.
	Insert card. Depending on the card type, it must be inserted in the chip card reader, held up to the contactless reader or swiped through the magnetic reader.
	Remove card.
	Sales slip printout.
	Request the customer's signature.
	Processing and/or communication.
	Manual entry of the card data. Press function button.



# 4 Menu tree (illustration)

## 4.1 MAIN MENU

To enter the menu tree below, press the <STOP> button.

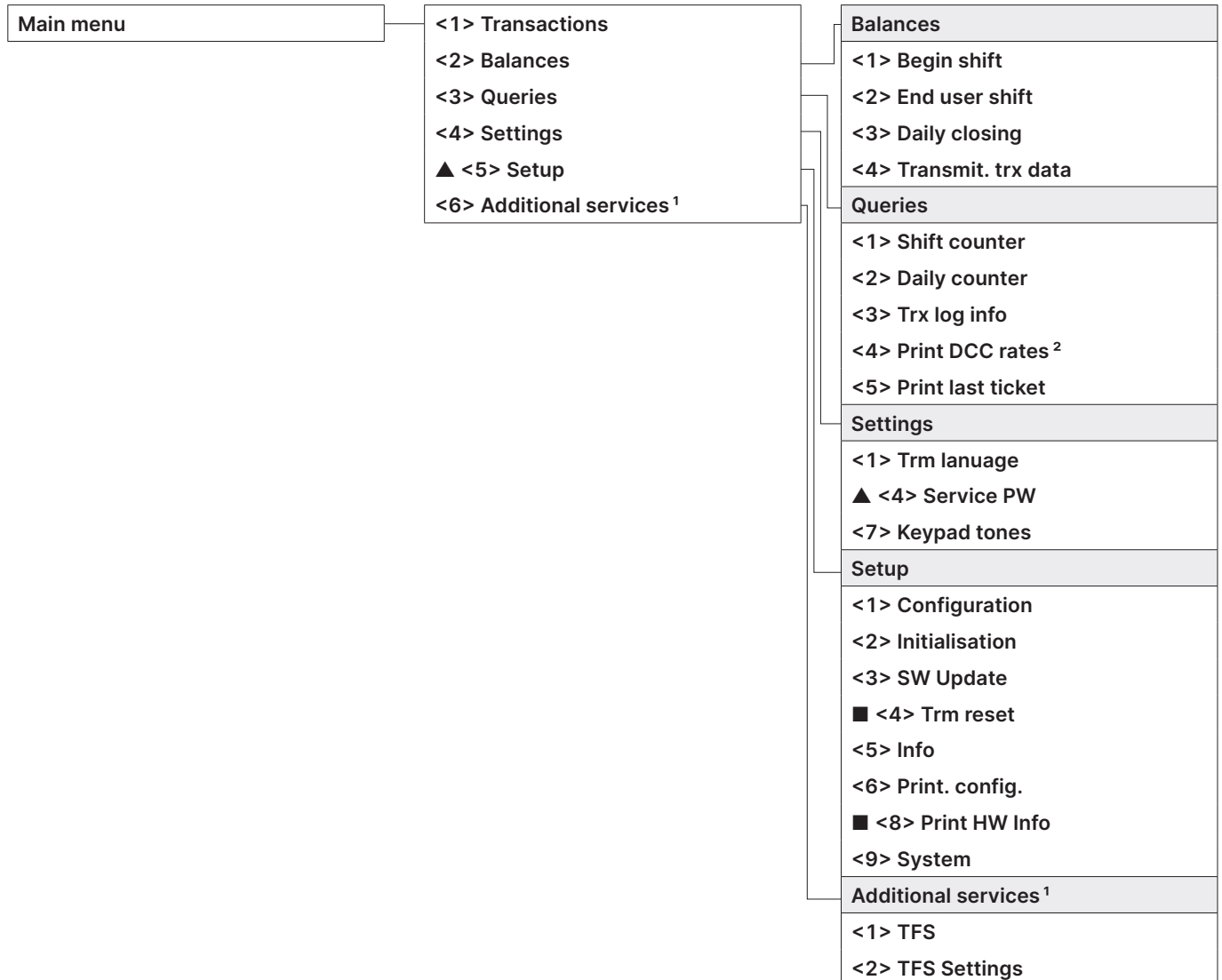

▲ Access only with your password. You can find this on the configuration sheet delivered with your terminal.  
 ■ Access only for service technicians.

<sup>1</sup> "Additional services" makes other optional services available.  
<sup>2</sup> This function may not be activated depending on the CCC.

## 4.2 TRANSACTIONS

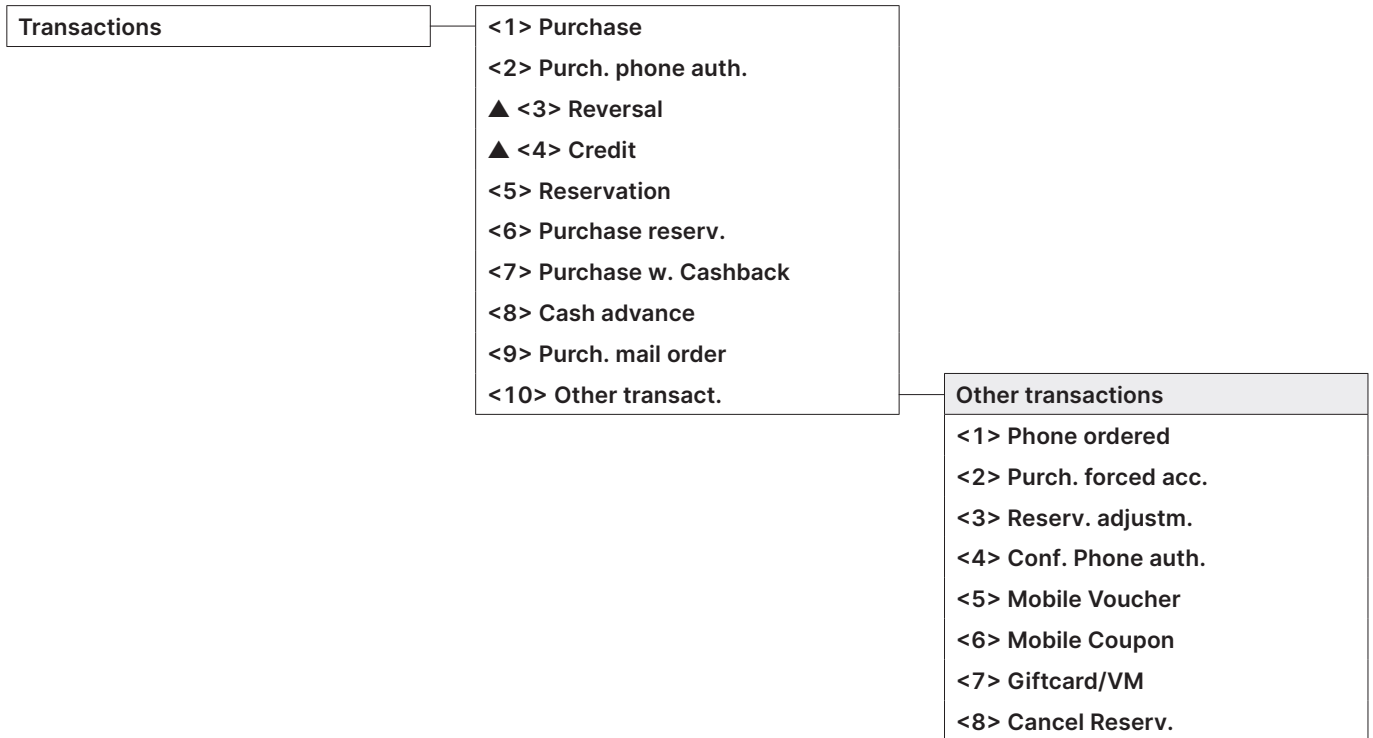

▲ Access only with your password. You can find this on the configuration sheet delivered with your terminal.

# 5 Transactions

## 5.1 PURCHASE

### <1> Purchase

The purchase is the most common transaction type in electronic payment traffic.

- Depending on the CCC, minimum/maximum amounts, day limits, etc. may vary.
- The “manual recording of card data” and “subsequent cancellation” functions are either activated or deactivated, depending on the CCC.

- YOMANI Touch XR Compact: If a transaction is not successful, then you will hear three short, acoustic signals that repeat every 2 seconds. This prompts the customer to give the terminal to the merchant. The reason for the problem is displayed by pressing on the special signals function button.

### Merchant handling

1	Press “1”. “Purchase” will be activated.	1 : Purchase
2*	If the “foreign currency” function is activated on your terminal, you must select the desired currency. <small>*Menu only appears if 2 or more currencies are activated.</small>	<Currency>
3	Enter the amount and confirm with <OK>. The amount must be separated with a decimal point. For amounts below CHF/EUR 1.00, a zero “0” must be entered first (e.g., CHF/EUR 0.55).	Amount <b>OK</b>
3a (DCC) <sup>1</sup>	If the cardholder prefers to make a transaction in CHF/EUR, this can be selected with the “CHF/EUR” function button.	
4	Proceed with card processing as detailed on <a href="#">pages 13 and 14</a> , or enter manually as detailed on <a href="#">page 12</a> .	

<sup>1</sup> This menu item is only shown if the Dynamic Currency Conversion (DCC) is activated. The terminal automatically recognizes if the card is one that is in a DCC-capable foreign currency and automatically chooses DCC. Otherwise, the transaction will be processed in the local currency. If the cardholder prefers to make a transaction in CHF/EUR, this can be selected with the “CHF/EUR” function button. As soon as the card has been read in, CHF/EUR can no longer be selected!

**Sample sales slip:** Certain fields may differ according to the purchase type.

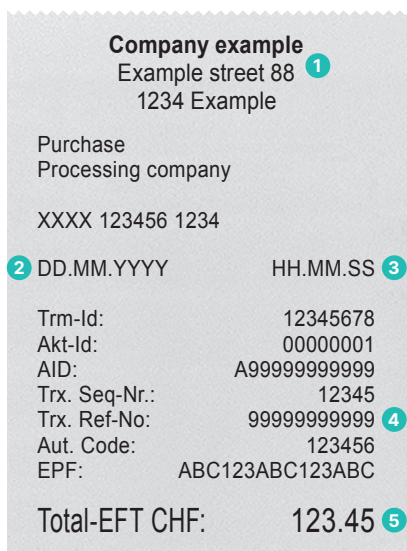

- 1** Your company data
- 2** Transaction date
- 3** Transaction time
- 4** Transaction information for unambiguous identification of the transaction
- 5** Amount

**Merchant: Manual card data entry**

Should a **credit card** be unreadable, the card data can be entered manually.

To do so, you need the card number, the expiry date, and depending on the CCC, the CVC/CVV (Card Verification

Code/Card Verification Value). This 3-digit code is printed on the reverse side of the card (the last three numbers).

After you have chosen the transaction mode and confirmed this by pressing <OK>, manual entry can be activated using the corresponding function button.

**YOMANI Touch XR Autonom/YOMANI Touch XR Compact**

1*	If the "foreign currency" function is activated on your terminal, you must select the desired currency. <small>*Menu appears only if two or more currencies are activated.</small>	<Currency>
2	Enter the amount and confirm with <OK>. The amount must be separated with a decimal point. For amounts below CHF/EUR 1.00, a zero "0." must be entered first.	Amount
3	Press the "Manual" button for manual recording.	
4	Enter the card number and press <OK>.	Card number
5	Enter the card expiry date and confirm with <OK>.	Expiry date
6	Enter the CVC2 respectively CVV2 and confirm with <OK>. <b>Tip!</b> For cards without a CVC, press <OK> <b>without</b> entering the CVC.	CVC2/CVV2 if present
7	Payment is recorded and authorised online, if this function is activated.	
8	A sales slip is printed out. The sales slip must be signed by the customer.	
9	If a copy is desired → press 1. If no copy is desired → press 2. If no button is pressed, the copy will be automatically printed out after 10 seconds.	1 : Copy or 2 : No copy

**YOMANI Touch XR Pinpad**

1	Enter the transaction on the cash register as usual.
2	On the customer terminal, press the <Corr> and <Menu> buttons in quick succession within half a second.
3	A request to enter the card details manually will be shown on the YOMANI Touch XR screen.

**Example:**

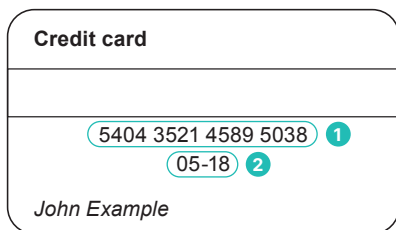

- 1 Card number
- 2 Expiry date
- 3 CVC2/CVV2

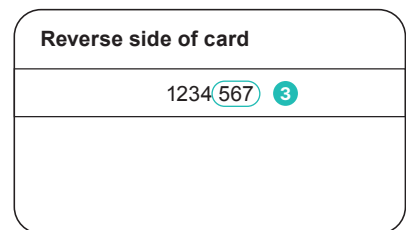





After the merchant enters the amount, the customer is prompted by the terminal to use his or her card.

Depending on the card type, the two following procedures are possible:

- Customer handling: card without PIN.
- Customer handling: card with PIN (see p. 14).





### Customer handling: Card without PIN

1	The amount is shown.							
2	Depending on the card type, it must be inserted in the chip card reader, held up to the contactless reader or pulled through the magnetic swipe reader. If the customer uses the wrong reader for his or her card, that person is instructed to use the proper reader.							
2a (TIP) <sup>1</sup>	If the TIP function is activated, after the original amount is confirmed, the option of entering a tip is also offered and confirmed by pressing <OK>. If the guest does not wish to give a tip, he/she can continue without entering an amount by pressing <OK>.	Tip: ..... <b>OK</b>						
2b (DCC) <sup>2</sup>	The customer chooses whether he or she wants to pay with DCC or in the local currency.	<table border="1"> <tr> <td>1. CHF</td> <td>100.00</td> </tr> <tr> <td>2. EUR</td> <td>66.33</td> </tr> <tr> <td>ExRate</td> <td>1.463486</td> </tr> </table>	1. CHF	100.00	2. EUR	66.33	ExRate	1.463486
1. CHF	100.00							
2. EUR	66.33							
ExRate	1.463486							
3	The amount is shown. Confirm the amount with <OK>.	<b>OK</b>						
4	Payment is recorded and authorized online if necessary.							
5	Remove the card.							
6	The sales slip is printed out. The sales slip must be signed by the customer.							
7	If a copy is desired → press 1. If no copy is desired → press 2. If no button is pressed, the copy will be automatically printed out after 10 seconds.	1 : Copy or 2 : No copy						

<sup>1</sup> This menu item is only shown if TIP is activated. This function is only activated for hotels and restaurants by the card organizations. In addition to the adjustments in the payment procedure, this modification also has an impact upon the payment receipt and the daily closing printout.

<sup>2</sup> This menu item is only shown if the Dynamic Currency Conversion (DCC) is activated. The terminal automatically recognizes if the card is one that is in a DCC-capable foreign currency and automatically chooses DCC. Otherwise, the transaction will be processed in the local currency. If the cardholder prefers to make a transaction in CHF/EUR, this can be selected with the "CHF/EUR" function button. As soon as the card has been read in, CHF/EUR can no longer be selected!

## Customer handling: Card with PIN

1	The amount is shown.							
2	Depending on the card type, it must be inserted in the chip card reader, held up to the contactless reader or swiped through the magnetic reader. If the customer uses the wrong reader for his or her card, that person is instructed to use the proper reader.							
2a (TIP) <sup>1</sup>	If the TIP function is activated, after the original amount is confirmed, the option of entering a tip is also offered and confirmed by pressing <OK>. If the guest does not wish to give a tip, he/she can continue without entering an amount by pressing <OK>.	Tip: ..... <b>OK</b>						
2b (DCC) <sup>2</sup>	The customer chooses whether he or she wants to pay with DCC or in the local currency.	<table border="1"> <tr> <td>1. CHF</td> <td>100.00</td> </tr> <tr> <td>2. EUR</td> <td>66.33</td> </tr> <tr> <td>ExRate</td> <td>1.463486</td> </tr> </table>	1. CHF	100.00	2. EUR	66.33	ExRate	1.463486
1. CHF	100.00							
2. EUR	66.33							
ExRate	1.463486							
3 (NFC) <sup>3</sup>	The total is displayed and the customer is requested to enter the PIN code (4- to 6-digit) and to confirm with <OK>. If the amount is incorrect, the transaction can be aborted using <STOP>. <b>Timeout:</b> The process will be aborted if the processing does not occur within 30 seconds.	<PIN> <b>OK</b>						
4	Payment is recorded and authorized online if necessary.							
5	Remove the card.							
6	The sales slip is printed out. The sales slip must be signed by the customer.							
7	If a copy is desired → press 1. If no copy is desired → press 2. If no button is pressed, the copy will be automatically printed out after 10 seconds.	1 : Copy or 2 : No copy						

<sup>1</sup> This menu item is only shown if TIP is activated. This function is only activated for hotels and restaurants by the card organizations. In addition to the adjustments in the payment procedure, this modification also has an impact upon the payment receipt and the daily closing printout.

<sup>2</sup> This menu item is only shown if the Dynamic Currency Conversion (DCC) is activated. The terminal automatically recognizes if the card is one that is in a DCC-capable foreign currency and automatically chooses DCC. Otherwise, the transaction will be processed in the local currency. If the cardholder prefers to make a transaction in CHF/EUR, this can be selected with the "CHF/EUR" function button. As soon as the card has been read in, CHF/EUR can no longer be selected!

<sup>3</sup> Generally, the PIN entry is not required for contactless payment of smaller amounts. However, this is controlled by the card issuer and may vary.



## 5.2 PURCHASE AUTHORIZED PER PHONE

### <2> Phone authorised

This purchase mode is used when the authorisation cannot be made automatically. The authorisation code is issued

by a CCC representative by telephone. With the function "Phone authorised", the transaction will be recorded later.

#### Merchant handling

1	Press "2". The "Phone authorized" function is activated.	2: Phone authorized
2*	If the "foreign currency" function is activated on this terminal, then the desired currency must be select. *Menu only appears if 2 or more currencies are activated.	<Currency>
3	Enter the amount and confirm with <OK>. The amount must be separated with a decimal point. For amounts below CHF/EUR 1.00, a zero "0" must be entered first (e.g., CHF/EUR 0.55).	Amount 
3a (DCC) <sup>1</sup>	If the cardholder prefers to make a transaction in CHF/EUR, this can be selected with the "CHF/EUR" function button.	
4	Enter the authorization code and confirm with <OK>.	Authorization code 
5	Card handling according to <a href="#">pages 13 and 14</a> , or <a href="#">page 12</a> for manual entry.	

<sup>1</sup> This menu item is only shown if the Dynamic Currency Conversion (DCC) is activated. The terminal automatically recognizes if the card is one that is in a DCC-capable foreign currency and automatically chooses DCC. Otherwise, the transaction will be processed in the local currency. If the cardholder prefers to make a transaction in CHF/EUR, this can be selected with the "CHF/EUR" function button. As soon as the card has been read in, CHF/EUR can no longer be selected!





## 5.3 CANCELLATION

### <3> Cancellation

The purchase which has **just been made** can be cancelled using the "Cancellation" function.

- With some CCC's this function may not be activated.
- If a daily closing or shift-end has been carried out in the meantime, or if the data has been transmitted, then cancellation is no longer possible.

#### Merchant handling



1	Press "3" to activate the "Cancellation" function.	3: Cancellation
2	Enter the terminal's password and confirm with <OK>. (See configuration sheet for the password.)	Password 
3	The amount of the last transaction is shown. If the amount of the last transaction is correct, then confirm this by pressing the <OK> button.	
4	Cancellation is recorded and, if necessary, authorised online.	
5	A sales slip is printed out.	
6	If a copy is desired → press 1. If no copy is desired → press 2. If no button is pressed, the copy will be automatically printed out after 10 seconds.	1 : Copy or 2 : No copy

## 5.4 CREDIT

### <4> Credit

A purchase that has been made can be corrected using the "Credit" function. This is used if a cancellation is no longer possible.

#### Merchant handling

1	Press "4". "Credit" will be activated.	4 : Credit
2	Enter the password and confirm with <OK>. (See the configuration sheet for the password)	Password 
3*	If the "foreign currency" function is activated on this terminal, then the desired currency must be selected. <small>*Menu only appears if 2 or more currencies are activated.</small>	<Currency>
4	Enter the amount and confirm with <OK>. The amount must be separated with a decimal point. For amounts below CHF/EUR 1.00, a zero "0" must be entered first (e.g., CHF/EUR 0.55).	Amount 
4a (DCC) <sup>1</sup>	If DCC is activated, then the date of the original transaction must also be entered.	Orig. Trx date (YYYYMMDD)
5	The amount is shown and the card requested.	
6	Card handling according to <a href="#">pages 13 and 14</a> , or <a href="#">page 12</a> for manual entry.  <b>The merchant signs the sales slip!</b>	

## 5.5 ADDITIONAL TRANSACTIONS

In addition to the payment types described, your terminal also contains other functions that are generally only used very rarely. The operation of these additional functions corresponds to the same logic as that used for the standard functions. Please follow the instructions issued by the terminal. Some examples are detailed below. Contact our hotline if you have difficulties with a function.

### <5> Reservation and

### <6> Purchase reserv.

#### (purchase of a previously made reservation)

With <5> Reservation (e.g., hotel, rental car, flight ticket, etc.) an amount can be booked to the credit card. The entire amount or even just a partial amount can be subsequently purchased with <6>.

### <8> Mail Order

Distance payment purchases are handled with Mail Order. In this case, the customer provides the card number, the expiry date (and the CVC, if needed) to the merchant by fax, mail or the Internet shop. If a contract for Mail Order has been signed, then the merchant generally can no longer carry out any normal bookings (<1> function).



# 6 Balances

## 6.1 START USER SHIFT/END USER SHIFT, DAILY CLOSING, DATA TRANSMISSION

<STOP> <2>

Balances

You can enter the terminal's main menu using the <STOP> button. Select the "Balances" function <2>. You then have the following options:

<STOP> <2> <1>

Begin user shift (o)

You can start a user shift autonomously when you begin working. If you attempt to make a transaction after the end of a shift or daily closing, then the terminal automatically starts a new shift.

<STOP> <2> <2>

End user shift (o)

With the "End user shift" function you end the current shift. Delivery of the transactions is carried out automatically. The daily closing, however, remains open.

- No further cancellations can be made after a shift end.
- No further tips can be recorded after a shift end.

<STOP> <2> <3>

Daily closing (m)

With the "Daily closing" function, all transactions that have been made are delivered to the card processors and completed. All amounts are credited to you after daily closing. a daily closing should be carried out at least once a day – preferably after the establishment has closed. The day and shift counter is set to "0".

- No further cancellations can be made after a daily closing.
- No further tips can be recorded after a daily closing.

<STOP> <2> <4>

Transmit trx data (o)

With the "Transmit trx data" function, all transactions that have been conducted and stored in the terminal are transmitted. This function should always be used if a large number of offline transactions has been made.

- No further cancellations can be made after a "Transmit trx data".
- No further tips can be recorded after a "Transmit trx data".

o = Optional: You can use this function according to your requirements.  
m = Mandatory

# 7 Queries (totals), settings

<STOP> <3>

Queries

You can enter the terminal's main menu using the <STOP> button. Select the "Queries" function <3>. You then have the following options:

<STOP> <3> <1>

Shift counter

The current status of the active shift is printed out.

<STOP> <3> <2>

Daily counter

The current status since the last daily closing is printed out.

<STOP> <3> <3>

Trx log info

The current status of transactions since the last data transmission is listed.

<STOP> <3> <4>

Print DCC rates

The current DCC exchange rate will be inquired online and then printed out.

<STOP> <3> <5>

Print last ticket

A copy of the last sales slip is printed out.

<STOP> <4>

Settings

You can enter the terminal's main menu using the <STOP> button. Select the "Settings" function <4>. You then have the following options:

<STOP> <4> <1>

Trm language

The terminal language can be adjusted.

This language setting is only applicable until the next service call. During the service call, the service host's language setting will be reactivated. If you prefer a permanent adjustment of the language setting, then this can be set by calling our hotline. The customer language corresponds to the card's language code.

<STOP> <4> <4>

Service PW

Set the service password for other transactions (e.g. Mobile Voucher).

<STOP> <4> <7>

Keypad tones

Adjust the volume of the keypad tones. The adjustment must be confirmed with <OK>.

# 8 Setup

<STOP> <5>

Setup → Password is requested

You can enter the terminal's main menu using the <STOP> button. Select the <Setup> function <5>. The following terminal-specific functions can be carried out. The following functions require a **password**. You can find your password in the "Configuration instructions for YOMANI Touch XR".

<STOP> <5> <1>

Configuration

The terminal calls the service centre and obtains the latest configuration parameters in the event that they have changed.

<STOP> <5> <2>

Initialisation

You can re-initialise individual or all activated card products.

<STOP> <5> <3>

SW Update

The terminal calls the service host and downloads the latest software version, if one exists. The software download may require several minutes. Please connect the terminal to the power supply for this purpose.

<STOP> <5> <4>

Trm Reset

This function is only available to the service technicians and is protected by a separate password.

<STOP> <5> <5>

Info

The terminal ID (TID) and the current software version are displayed.

<STOP> <5> <6>

Print config

The current configuration can be printed out.  
→ Please note that the detailed printout may require a great deal of paper.

<STOP> <5> <8>

Print hardware info

This function is only available to service technicians and is protected by a separate password.

<STOP> <5> <9>

System

This function is only available to the service technicians, and we recommend that you only use the function if requested to do so by our hotline.

# 9 Additional services

<STOP> <6>

Additional services

---

Pressing the <STOP> button takes you to the main menu of the terminal. Select function <6> Additional services. The terminal-specific functions indicated can be executed.

<STOP> <6> <1>

TFS Settings

---

This menu leads to the Tax-Free Service settings.

<STOP> <6> <2> <1>

Activate Tax-Free

---

In this sub-menu, the Tax-Free Service of the desired provider can be activated.

<STOP> <6> <2> <5>

Deactivate TFS

---

In this sub-menu, the Tax-Free Service of the provider used can be deactivated.

# 10 Maintenance and handling

## 10.1 IDENTIFYING AND SOLVING ERRORS

### No display

Check that all the leads are properly connected.

**Important:**  
Always connect the power supply last.

### Terminated, no connection

Check that the terminal is properly connected.  
Check that the telephone line is active.

### Host timeout

The corresponding computer center does not reply.  
Possible reason: network overload.

### Reading error, card cannot be read

Clean the reading unit. Card information can also be entered manually.

### Status display and tool

1	Screen messages must be confirmed using the <OK> button.	All screen messages on the terminal must be confirmed with <OK>.
2	Special signal – an audible warning signal sounds during the payment procedure.	When general errors occur during the payment procedure, the terminal will repeatedly sound an audible warning signal and the request “terminal back to merchant please” will appear on the display. This message can be stopped by pressing the left function key on the display.



**PLEASE NOTE!** Worldline carries out software updates at night in order to enable you to use your payment terminal without interruption during the day. For this reason, **your payment terminal must be left switched on at night with a constant Internet connection.**

## 10.2 CHANGING THE PAPER ROLL

### YOMANI Touch XR Autonom

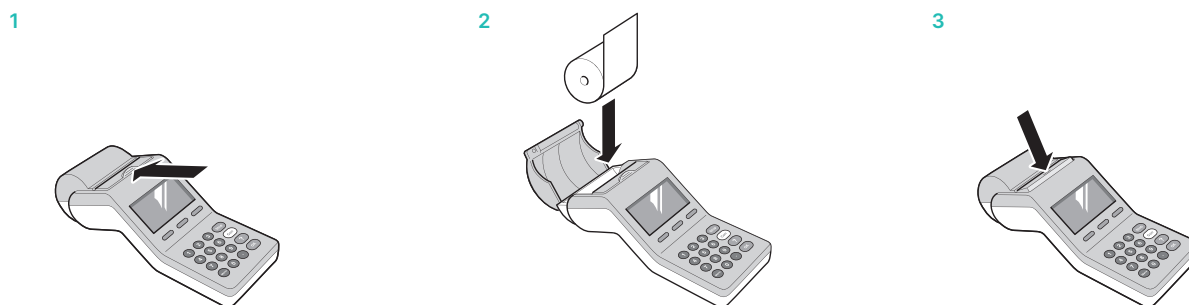

### YOMANI Touch XR Compact/YOMANI Touch XR Pinpad Printer

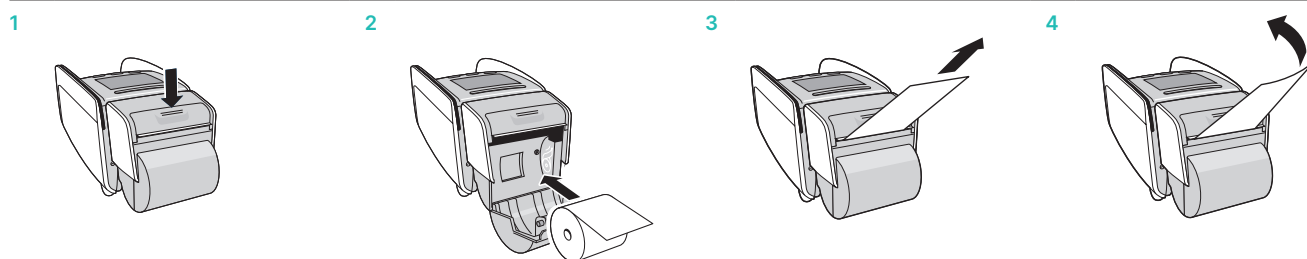

### Troubleshooting

If printing is impossible, check whether the paper roll has been inserted backwards.

Do not pull the paper out if the printer cover is closed.

Your local point of contact can be found at: [worldline.com/merchant-services/contacts](https://worldline.com/merchant-services/contacts)

